

CAPACITY 6000 LBS.

INFORMATION REQUIRED
SEE SHEET 2 FOR SPECIFICATIONS

TRACK SIZE: _____

FLANGE WIDTH: _____

FLANGE THICKNESS: _____

HARDENED WHEELS:

- NO
 YES

DIMENSION "A": _____

SPACER REQUIRED:
 NO
 YES

DIMENSION "B": _____

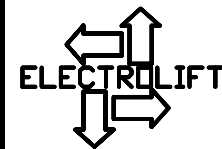

ELECTROLIFT, INC.
204 SARGEANT AVE.
CLIFTON, NJ 07013
PH: 973-471-0204
FAX: 973-471-2814
www.electrolift.com

| | | | |
|------|------|------|-----|
| REV. | ECO# | DATE | BY: |
|------|------|------|-----|

IDLER TROLLEY PART NUMBER: M1196B

| | | | |
|----------------|-------------|-------------|--------------|
| DATE: 12/12/07 | SCALE: NONE | DWG SIZE: A | DRAWN BY: DR |
|----------------|-------------|-------------|--------------|

DRAWING NO.:

M1196B-WPDF

SHEET 1 OF 2

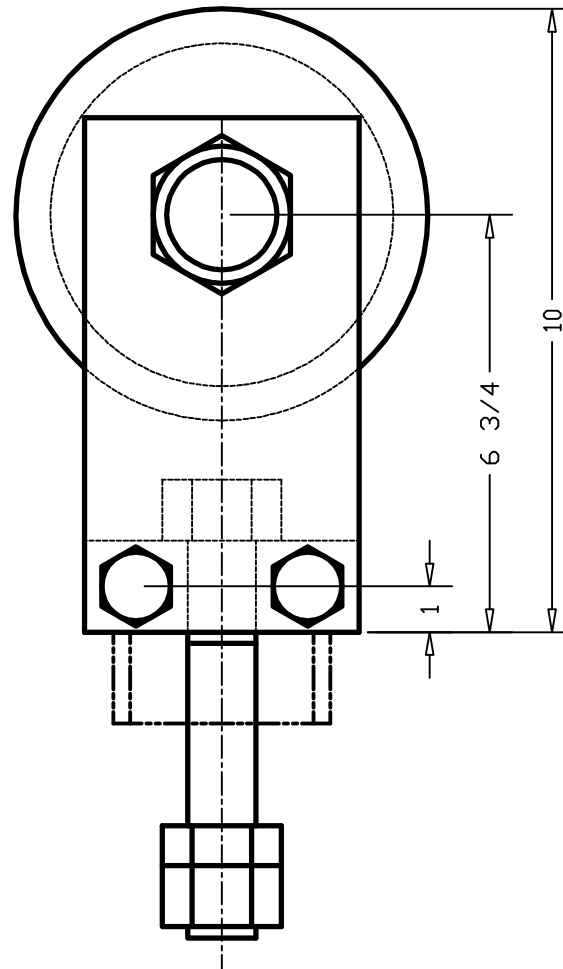
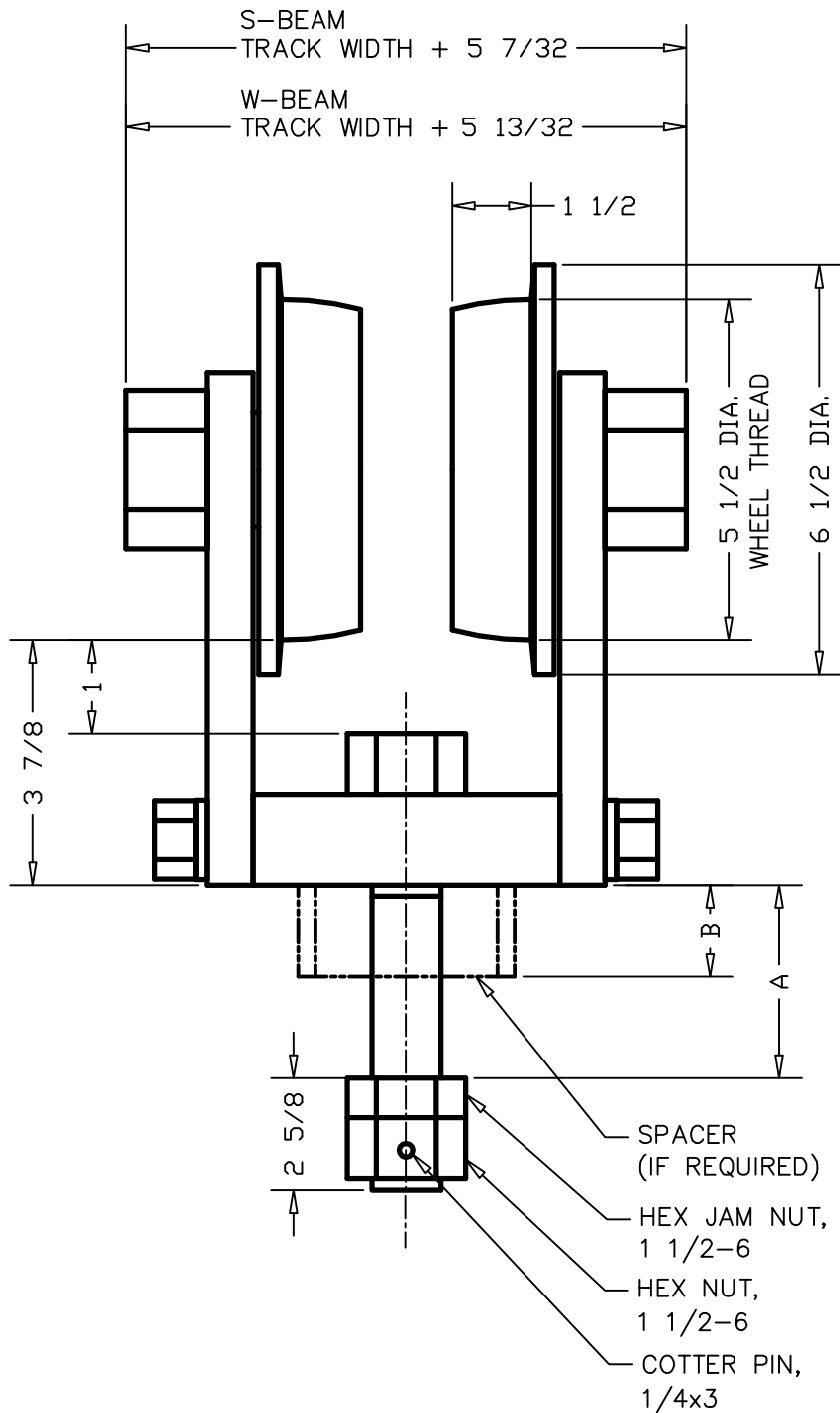

CAPACITY 6000 LBS.

SPECIFICATIONS

PROVIDE SHEET 1 TO ELECTROLIFT

GENERAL NOTES:

1. CAPACITY OF TROLLEY IS NOT TO BE EXCEEDED
2. FACTOR OF SAFETY 5 TO 1 MINIMUM
3. VISTA GREEN ENAMAL PAINT STANDARD
4. NOT DESIGNED FOR TRAVERSING TRACKS WITH A RADIUS.
5. CONSULT ELECTROLIFT'S SALES DEPARTMENT FOR ADDITIONAL FEATURES

WHEEL ASSEMBLY

STANDARD HARDNESS:

BRINELL 143/ROCKWELL B78

OPTIONAL HARDENED WHEEL:

BRINELL 475/ROCKWELL C50

BEARING L10HR LIFE:

18,315 HRS AT 50 FPM

TRACK TYPE

S-BEAM TRACK: CURVED PROFILE AS SHOWN

W-BEAM TRACK: FLAT PROFILE PROVIDED

PATENTED TRACK: SEE TROLLEY M2571C

SPACER LENGTH

REQUIRED IF DIMENSION "C"

EXCEEDS 1/2"

MATERIAL = TUBING, 2 IDx2-3/8 OD

BOLT SPAN

5 7/16" MAX.

FOR LARGER DIMENSIONS, CONTACT ELECTROLIFT

GAP

1/8" MIN. GAP REQUIRED FROM BOTTOM OF YOKE OR SPACER TO BOTTOM OF FRAME

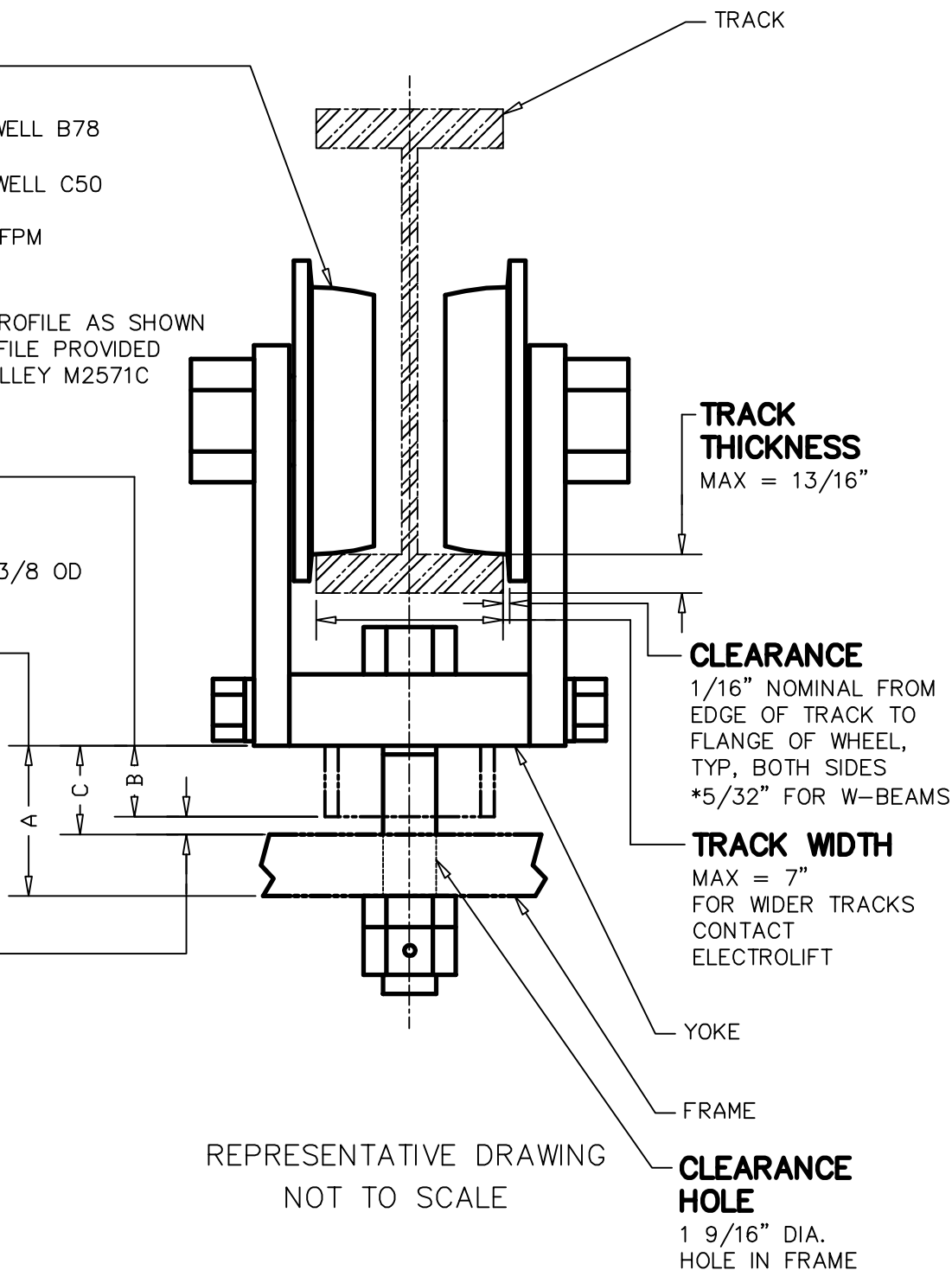

REPRESENTATIVE DRAWING
NOT TO SCALE

CLEARANCE HOLE

1 9/16" DIA.
HOLE IN FRAME

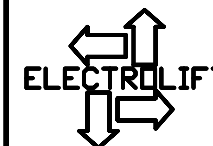

ELECTROLIFT, INC.
204 SARGEANT AVE.
CLIFTON, NJ 07013
PH: 973-471-0204
FAX: 973-471-2814
www.electrolift.com

| | | | |
|----------------------------|--------|-----------|-----------|
| REV. | ECO# | DATE | BY: |
| IDLER TROLLEY PART NUMBER: | | M1196B | |
| DATE: | SCALE: | DWG SIZE: | DRAWN BY: |
| 12/12/07 | NONE | A | DR |

DRAWING NO:
M1196B-WPDF
SHEET 2 OF 2