

CAPACITY 3000 LBS.

INFORMATION REQUIRED
SEE SHEET 2 FOR SPECIFICATIONS

TRACK SIZE: _____

FLANGE WIDTH: _____

FLANGE THICKNESS: _____

HARDENED WHEELS:

NO
 YES

DIMENSION "A": _____

SPACER REQUIRED:
 NO
 YES

DIMENSION "B": _____

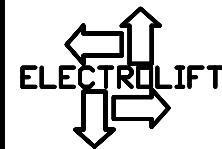

ELECTROLIFT, INC.
204 SARGEANT AVE.
CLIFTON, NJ 07013
PH: 973-471-0204
FAX: 973-471-2814
www.electrolift.com

REV.	ECO#	DATE	BY:
------	------	------	-----

IDLER TROLLEY PART NUMBER: M1241B

DATE: 12/12/07	SCALE: NONE	DWG SIZE: A	DRAWN BY: DR
----------------	-------------	-------------	--------------

DRAWING NO:

M1241B-WPDF
SHEET 1 OF 2

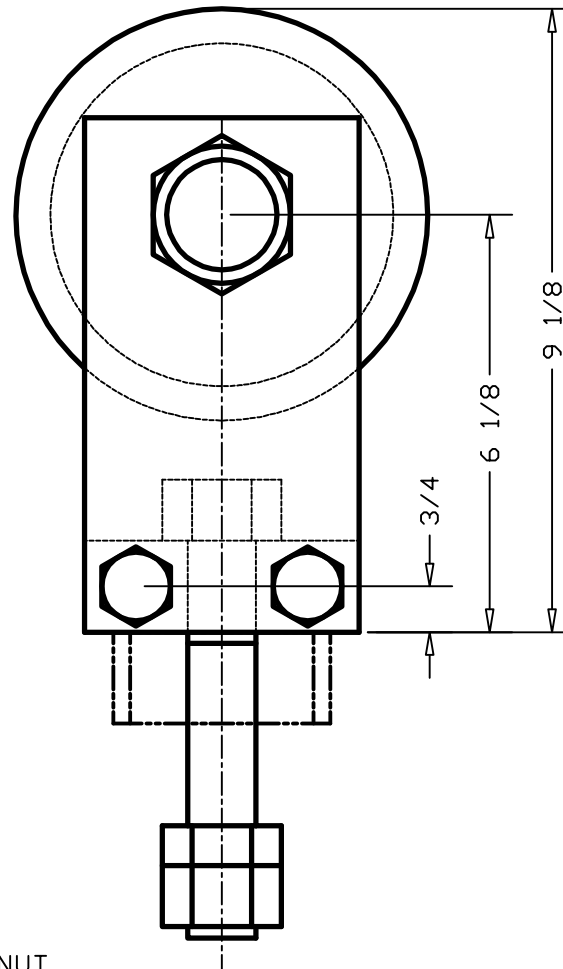
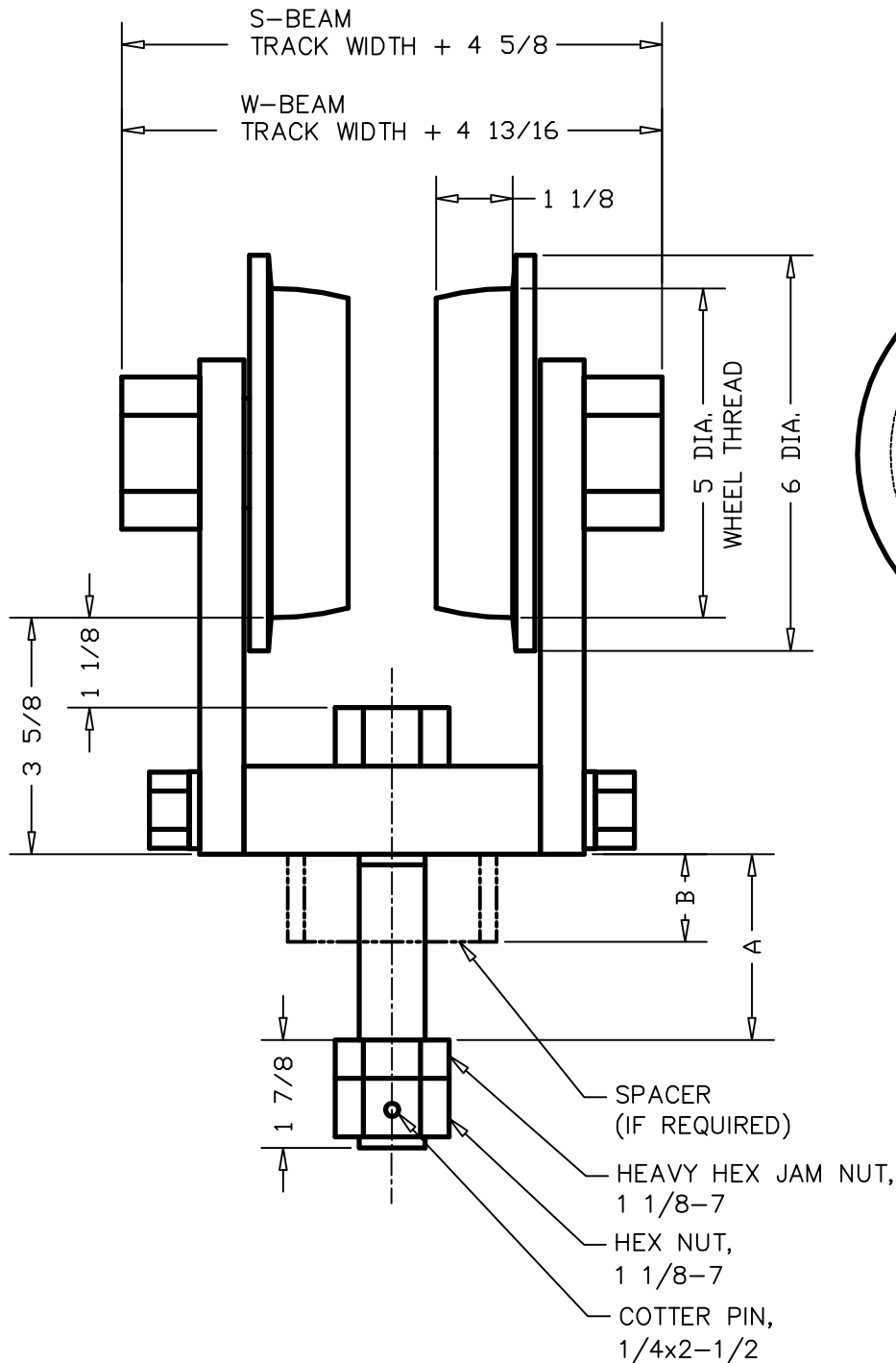

CAPACITY 3000 LBS.

SPECIFICATIONS

PROVIDE SHEET 1 TO ELECTROLIFT

GENERAL NOTES:

1. CAPACITY OF TROLLEY IS NOT TO BE EXCEEDED
2. FACTOR OF SAFETY 5 TO 1 MINIMUM
3. VISTA GREEN ENAMAL PAINT STANDARD
4. NOT DESIGNED FOR TRAVERSING TRACKS WITH A RADIUS.
5. CONSULT ELECTROLIFT'S SALES DEPARTMENT FOR ADDITIONAL FEATURES

WHEEL ASSEMBLY

STANDARD HARDNESS:

BRINELL 143/ROCKWELL B78

OPTIONAL HARDENED WHEEL:

BRINELL 475/ROCKWELL C50

BEARING L10HR LIFE:

11,393 HRS AT 50 FPM

TRACK TYPE

S-BEAM TRACK: CURVED PROFILE AS SHOWN

W-BEAM TRACK: FLAT PROFILE PROVIDED

PATENTED TRACK: SEE TROLLEY M1271B

SPACER LENGTH

REQUIRED IF DIMENSION "C"

EXCEEDS 1/2"

MATERIAL = TUBING, 2 IDx2-3/8 OD

BOLT SPAN

1 3/4" MAX.

FOR LARGER

DIMENSIONS,

CONTACT

ELECTROLIFT

GAP

1/8" MIN. GAP REQUIRED

FROM BOTTOM OF YOKE

OR SPACER TO BOTTOM

OF FRAME

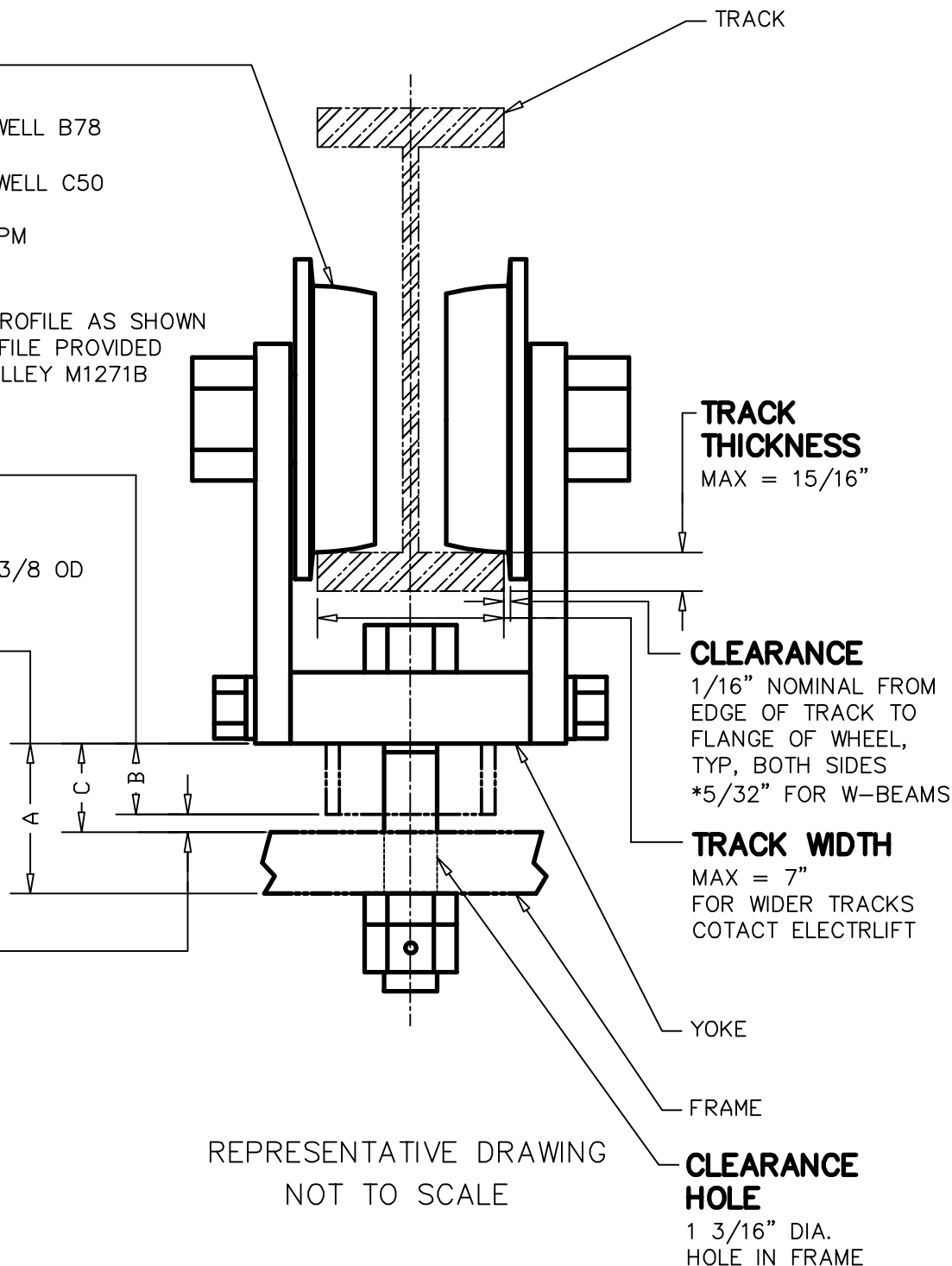

REPRESENTATIVE DRAWING
NOT TO SCALE

CLEARANCE HOLE

1 3/16" DIA.
HOLE IN FRAME

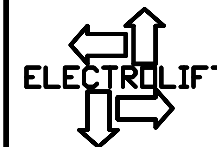

ELECTROLIFT, INC.
204 SARGEANT AVE.
CLIFTON, NJ 07013
PH: 973-471-0204
FAX: 973-471-2814
www.electrolift.com

REV.	ECO#	DATE	BY:
IDLER TROLLEY PART NUMBER:		M1241B	
DATE: 12/12/07	SCALE: NONE	DWG SIZE: A	DRAWN BY: DR
DRAWING NO:			
M1241B-WPDF			
SHEET 2 OF 2			