

UNDERHUNG TROLLEYS  
TOP MOUNTED HOIST

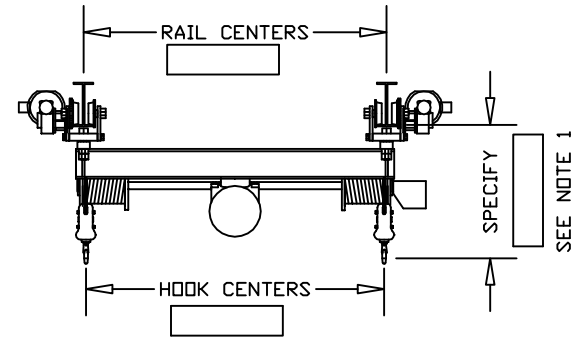

UNDERHUNG TROLLEYS  
BOTTOM MOUNTED HOIST

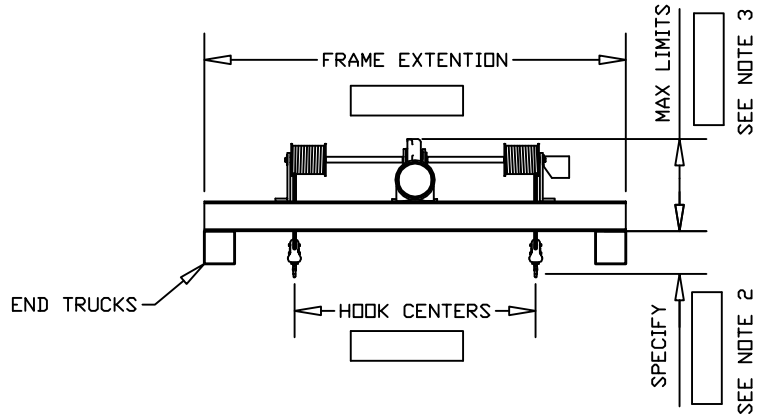

END TRUCKS  
TOP MOUNTED HOIST

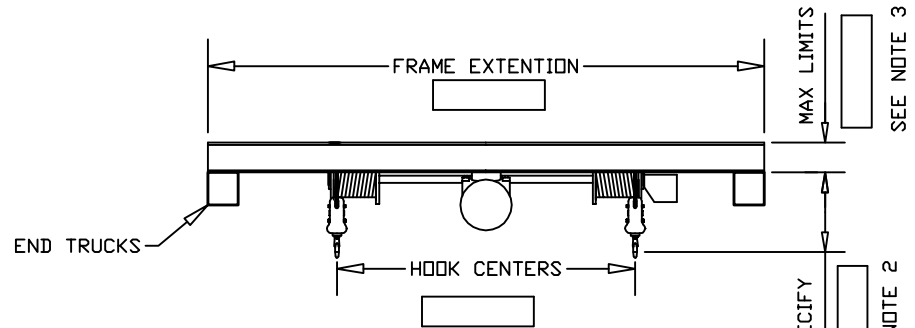

END TRUCKS  
BOTTOM MOUNTED HOIST

NOTES:

1. TREAD OF TRACK TO PALM OF HOOK
2. BOTTOM OF FRAME TO PALM OF HOOK
3. IF NO DIMENSIONAL LIMITATIONS EXIST, MARK 'NONE'

TWIN HOOK DUAL RAIL  
CONFIGURATIONS

SHEET 1 OF 2

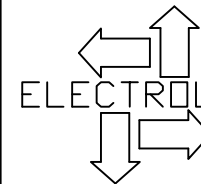

ELECTROLIFT  
ELECTROLIFT, INC.  
204 SARGEANT AVE.  
CLIFTON, NJ 07013  
PH: 973-471-0204

[www.electrolift.com](http://www.electrolift.com)

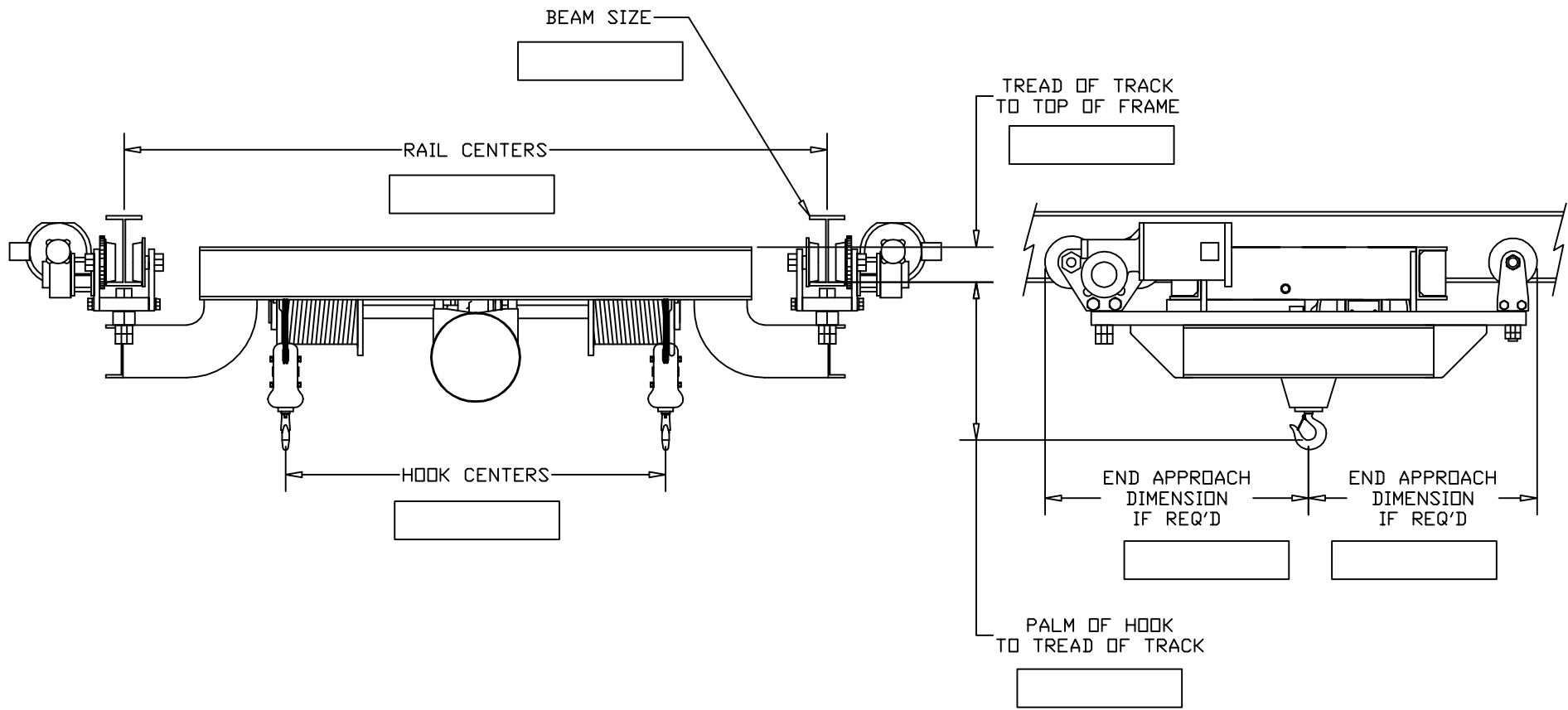

NOTE:  
 FILL IN ALL REQUIRED DIMENSIONS. IF THERE IS NO  
 DIMENSIONAL LIMITATION, MARK THE BOX 'NONE'

TWIN HOOK DUAL RAIL LOW HEAD  
 CRITICAL DIMENSIONS  
 SHEET 2 OF 2

ELECTROLIFT

ELECTROLIFT, INC.  
 204 SARGEANT AVE.  
 CLIFTON, NJ 07013  
 PH: 973-471-0204

[www.electrolift.com](http://www.electrolift.com)