

# ELECTRO LIFT, INC.

204 SARGEANT AVENUE, P.O. BOX 827, CLIFTON NJ 07013  
TELEPHONE 800-338-9951  
FAX NUMBER 973-471-2814  
[WWW.ELECTROLIFT.COM](http://WWW.ELECTROLIFT.COM)

## HOW TO ASSEMBLE AN ELECTRO LIFT BRAKE

The following is a basic procedure typical for Electro Lift Brakes:

1. ATTACH MOUNTING PLATE TO BRAKE ADAPTER USING SCREW AND LOCKWASHER.
2. APPLY ANTI SEIZE COMPOUND TO BRAKE PINION KEY, KEYWAY IN HUB, INSIDE OF BRAKE PINION AND KEYWAY ON MOTOR SHAFT.
3. INSTALL HUB TO MOTOR SHAFT. HUB MUST SIT PAST THE SNAP RING GROOVE OF THE MOTOR SHAFT.
4. APPLY ANTI-SEIZE COMPOUND TO BRAKE STUD AND STUD THREADS ON MOUNTING PLATE.



5. FINGER-TIGHTEN STUD TO MOUNTING PLATE. THREAD AN AIR GAP NUT ONTO BRAKE STUD, THEN TIGHTEN STUD TO PLATE USING A WRENCH ON THE NUT. DO NOT USE PLIERS OR VISE GRIPS TO TIGHTEN.



6. USE A BRAKE COVER TO INSURE THE STUDS ARE PARALLEL WITH EACH OTHER. IF STUDS ARE NOT PARALELL, USE A SOFT MALLETT AND TAP STUD TO ADJUST.

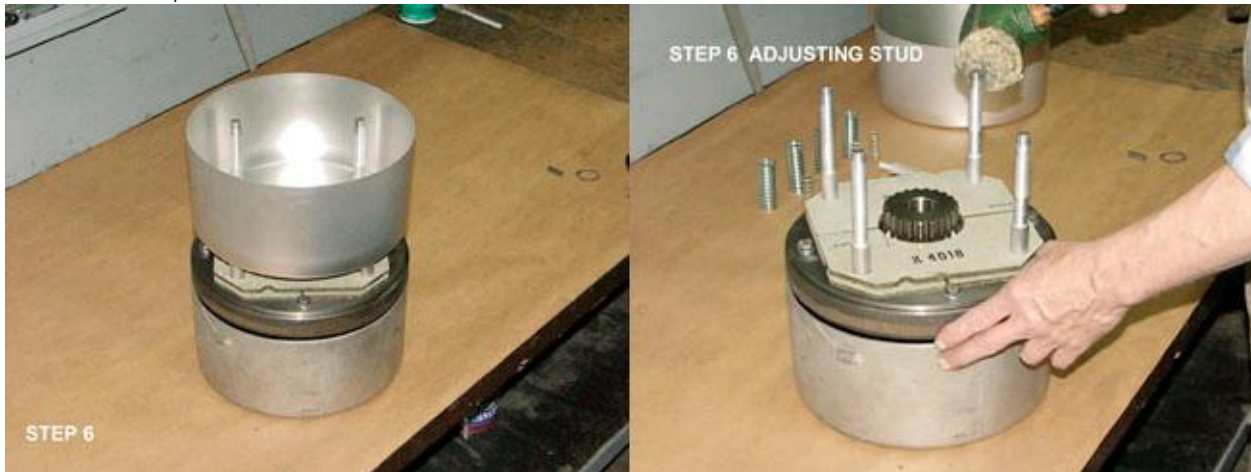

7. INSTALL BRAKE LINING. MAKE SURE CUT OUT OF LINING IS ON SAME SIDE OF THE BRAKE AS HOLE IN MOUNTING PLATE. THERE SHOULD BE VERY LITTLE DRAG AND NO HANG UP OF BRAKE LINING WHEN INSTALLING ON THE STUDS.

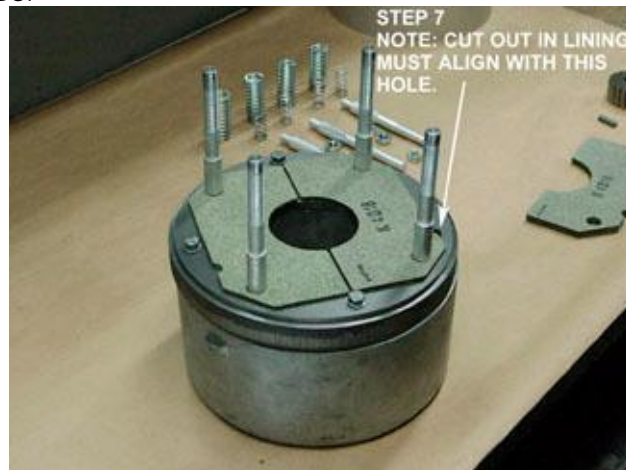

- CLEAN THE SURFACES OF THE ROTATING DISC AND INSTALL ONTO BRAKE HUB. IF BRAKE IS A DOUBLE OR TRIPLE DISC BRAKE, RAISED HUB OF DISC MUST FACE MOTOR.



- INSTALL INTERMEDIATE DISC. WHEN INSTALLING DISC MAKE SURE IT MOVES FREELY DOWN STUDS. \*
- CLEAN SURFACES OF ROTATING DISC AND INSTALL ONTO BRAKE HUB. IF BRAKE IS A DOUBLE DISC OR TRIPLE DISC BRAKE, RAISED HUB OF DISC MUST FACE MOTOR. \*
- INSTALL BRAKE LINING ROTATED 90 DEGREES FROM FIRST LINING.



\*IF BRAKE IS DOUBLE DISC OR TRIPLE DISC.

12. CLEAN SURFACE OF ARMATURE PLATE. CHECK SHADING COILS AND INSURE THAT ALL THE COILS ARE TIGHT. ANY LOOSE COILS MUST BE TIGHTENED. INSTALL ARMATURE PLATE, MAKE SURE PLATE MOVES FREELY OVER STUDS.



13. INSTALL INTERNAL SPRINGS.

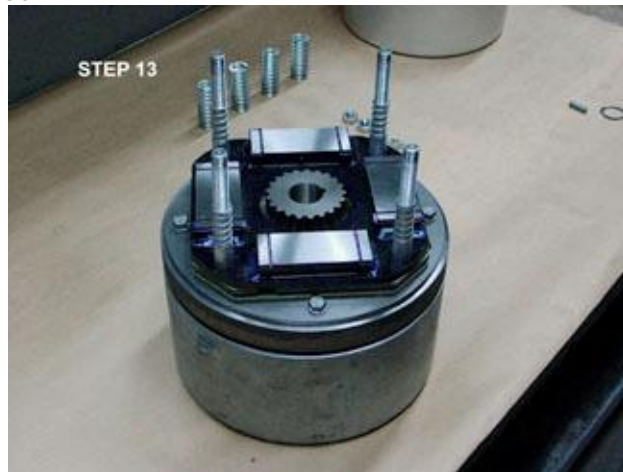

14. INSTALL EXTERNAL SPRINGS.





15. CLEAN SURFACE OF MAGNET PLATE. INSPECT FOR LOOSE RIVETS AND COIL CLIPS. INSPECT COILS FOR CUT OR BROKEN WIRES. INSTALL MAGNET PLATE, MAKE SURE MAGNET PLATE MOVES FREELY OVER STUDS.



16. APPLY ANTI SEIZE COMPOUND TO THREADS OF THE BRAKE STUDS AND AIRGAP NUTS. THREAD AN AIRGAP NUT ONTO STUD #1 AND #2 UNTIL AN AIRGAP OF APPROXIMATELY .020" \*\* IS BETWEEN THE ARMATURE PLATE AND MAGNET PLATE.



17. THREAD AN AIRGAP NUT ONTO BRAKE STUDS #3 AND #4 (SEE ABOVE PHOTO) UNTIL THE NUTS COME IN CONTACT WITH THE MAGNET PLATE.  
18. THREAD THE REMAINING AIRGAP NUTS ONTO STUDS UNTIL THEY COME IN CONTACT WITH THE AIRGAP NUTS ON THE STUDS.

\*\* DOUBLE DISC GAP IS .040"; TRIPLE DISC GAP IS .060".

19. POSITION A GAUGE OF THE APPROPRIATE GAP FOR THE BRAKE BEING ASSEMBLED ABOVE A POLE ON THE ARMATURE PLATE WHERE A SHADING COIL IS LOCATED. TIGHTENED THE FIRST AIRGAP NUT CLOSEST TO THE MAGNET PLATE, THAN TIGHTEN THE SECOND AIRGAP NUT. (SEE DIAGRAM FOR POSITIONS) IT MAY BE NECESSARY TO PERFORM THIS ADJUSTMENT SEVERAL TIMES IN ORDER TO ACHIEVE PROPER AIRGAP BETWEEN MAGNET PLATE AND ARMATURE PLATE.



## **RECOMMENDED PARTS TO KEEP IN STOCK**

- 4 – COILS
- 2 – LININGS
- 4 – STUDS
- 1,2 or 3- ROTATING DISC(S)\*

## **AIRGAP ADJUSTMENT**

BEFORE AIR GAP ADJUSTMENT IS MADE INSPECT BRAKE LININGS #7 AND ROTATING DISC #8. WHEN THICKNESS OF LINING IS .09375" OR LESS, THE LINING MUST BE REPLACED. WHEN THICKNESS OF ROTATING DISC FOR A SINGLE DISC IS .15" OR LESS, REPLACE ROTATING DISC. WHEN THICKNESS OF A ROTATING DISC FOR A TRIPLE OR DOUBLE DISC IS .10" OR LESS, REPLACE THE DISC.

THE AIR GAP IS SET AT THE FACTORY AT .020" FOR SINGLE DISC BRAKES, .040" FOR DOUBLE DISC BRAKES, AND .060" FOR TRIPLE DISC BRAKES. ADJUSTMENT TO COMPENSATE FOR WEAR CAN BE MADE SIMPLY BY MOVEMENT OF THE AIR GAP NUTS #14 INDICATED ON THE ACCOMPANYING PARTS LISTS. THE NUTS MUST BE LOCKED TIGHTLY WHEN ADJUSTMENT IS COMPLETE.

\*Dependant on amount of discs in brake.

## **TROUBLESHOOTING**

### **A. BRAKE CHATTERS/RATTLES:**

1. CHECK AIRGAP, ADJUST IF NECESSARY
2. INSURE SHADING COILS ARE IN PLACE AND SECURE.
3. IF HOIST USES A FREQUENCY DRIVE MAKE SURE BRAKE HAS IT'S OWN CONTACTOR.
4. DEFECTIVE BRAKE COIL/COILS.

### **B. NEW COIL INSTALLED BRAKE CHATTERS/RATTLES:**

1. CHECK WIRING OF BRAKE COILS PER WIRING DIAGRAM.
2. COIL VOLTAGE WAS INCORRECT, CONFIRM COIL NUMBER STAMPED ON COIL WITH ELECTRO LIFT

# WIRING DIAGRAMS

CONNECTION DIAGRAM FOR SINGLE VOLTAGE, 3 PHASE MOTORS

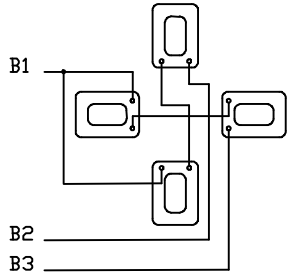

BRAKE COIL CONNECTIONS

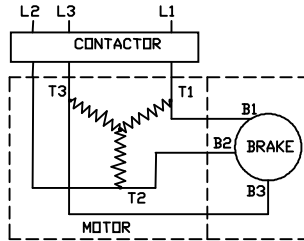

SINGLE VOLTAGE MOTOR & BRAKE ON 208V OR 575V

CONNECTION DIAGRAM FOR SINGLE PHASE MOTORS

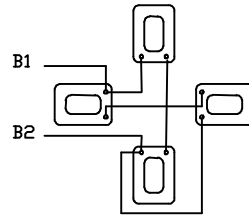

BRAKE COIL CONNECTIONS

CONNECTION DIAGRAM FOR DUAL VOLTAGE, 3 PHASE MOTORS

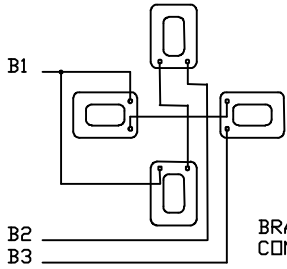

BRAKE COIL CONNECTIONS

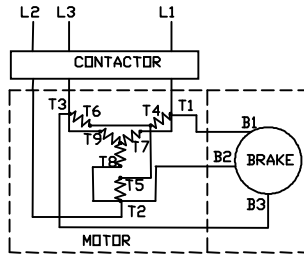

460/230 VOLTAGE MOTOR & BRAKE ON 230V

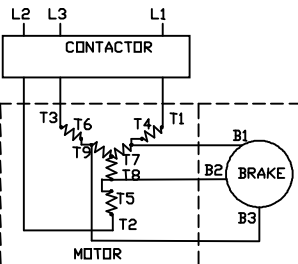

460/230 DUAL VOLTAGE MOTOR WITH BRAKE ON 230V & MOTOR ON 460V

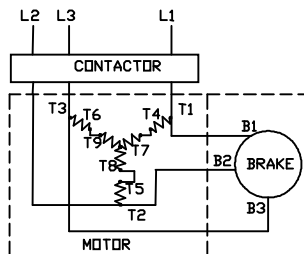

460/230 VOLTAGE MOTOR & BRAKE ON 460V

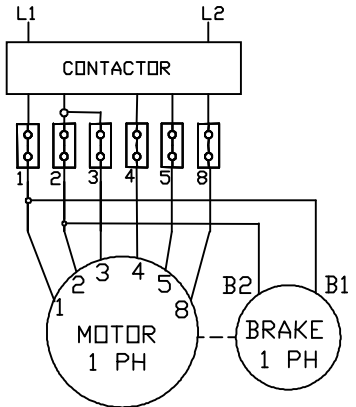

SINGLE PHASE MOTOR & SINGLE PHASE BRAKE

CONNECTION DIAGRAM FOR 2 SPEED, 3 PHASE MOTORS

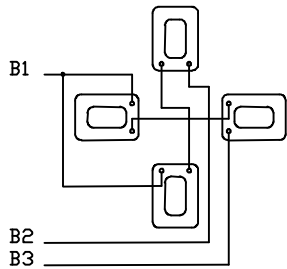

BRAKE COIL CONNECTIONS

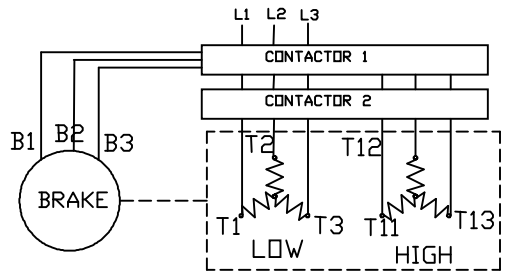

2 SPEED 460/230 VOLTAGE MOTOR & BRAKE ON 460V OR 230V

CONNECTION DIAGRAM FOR DC COIL CONFIGURATION

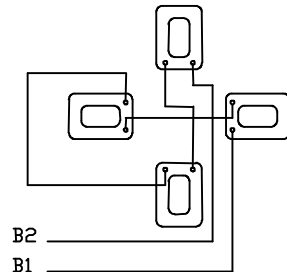



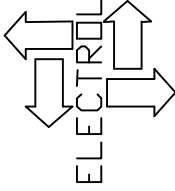

204 SARGEANT AVENUE  
CLIFTON, NJ 07013

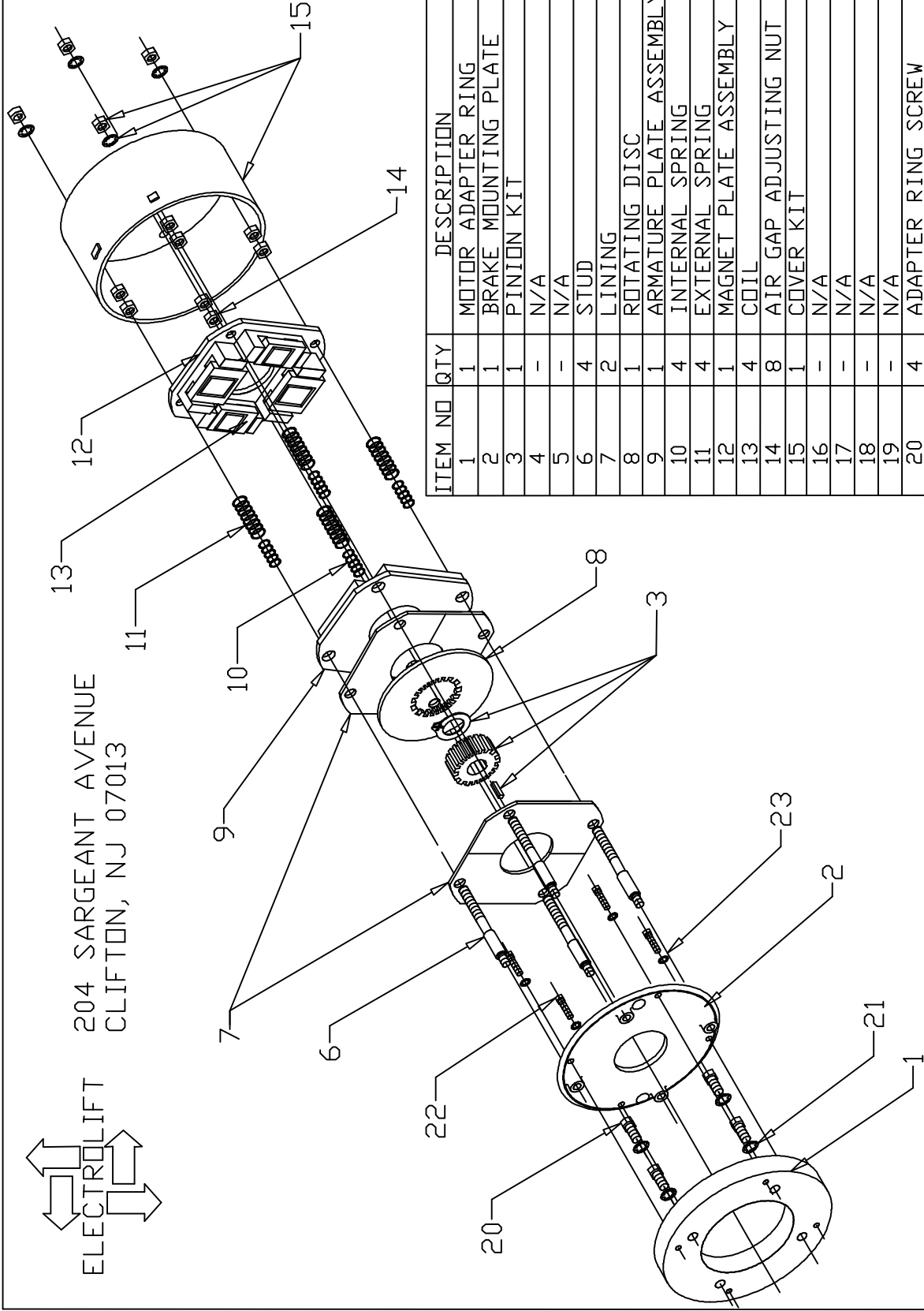

ITEM NO	QTY	DESCRIPTION
1	1	MOTOR ADAPTER RING
2	1	BRAKE MOUNTING PLATE
3	1	PINION KIT
4	-	N/A
5	-	N/A
6	4	STUD
7	2	LINING
8	1	ROTATING DISC
9	1	ARMATURE PLATE ASSEMBLY
10	4	INTERNAL SPRING
11	4	EXTERNAL SPRING
12	1	MAGNET PLATE ASSEMBLY
13	4	COIL
14	8	AIR GAP ADJUSTING NUT
15	1	COVER KIT
16	-	N/A
17	-	N/A
18	-	N/A
19	-	N/A
20	4	ADAPTER RING SCREW
21	4	ADAPTER RING LOCK WASHER
22	4	BRAKE MOUNTING PLATE SCREW
23	4	BRAKE MOUNTING PLATE LOCK WASHER

SHEET 831-1  
REV-1

ELECTRO LIFT SINGLE DISC PACKAGE BRAKE

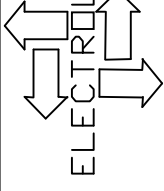

204 SARGEANT AVENUE  
CLIFTON, NJ 07013

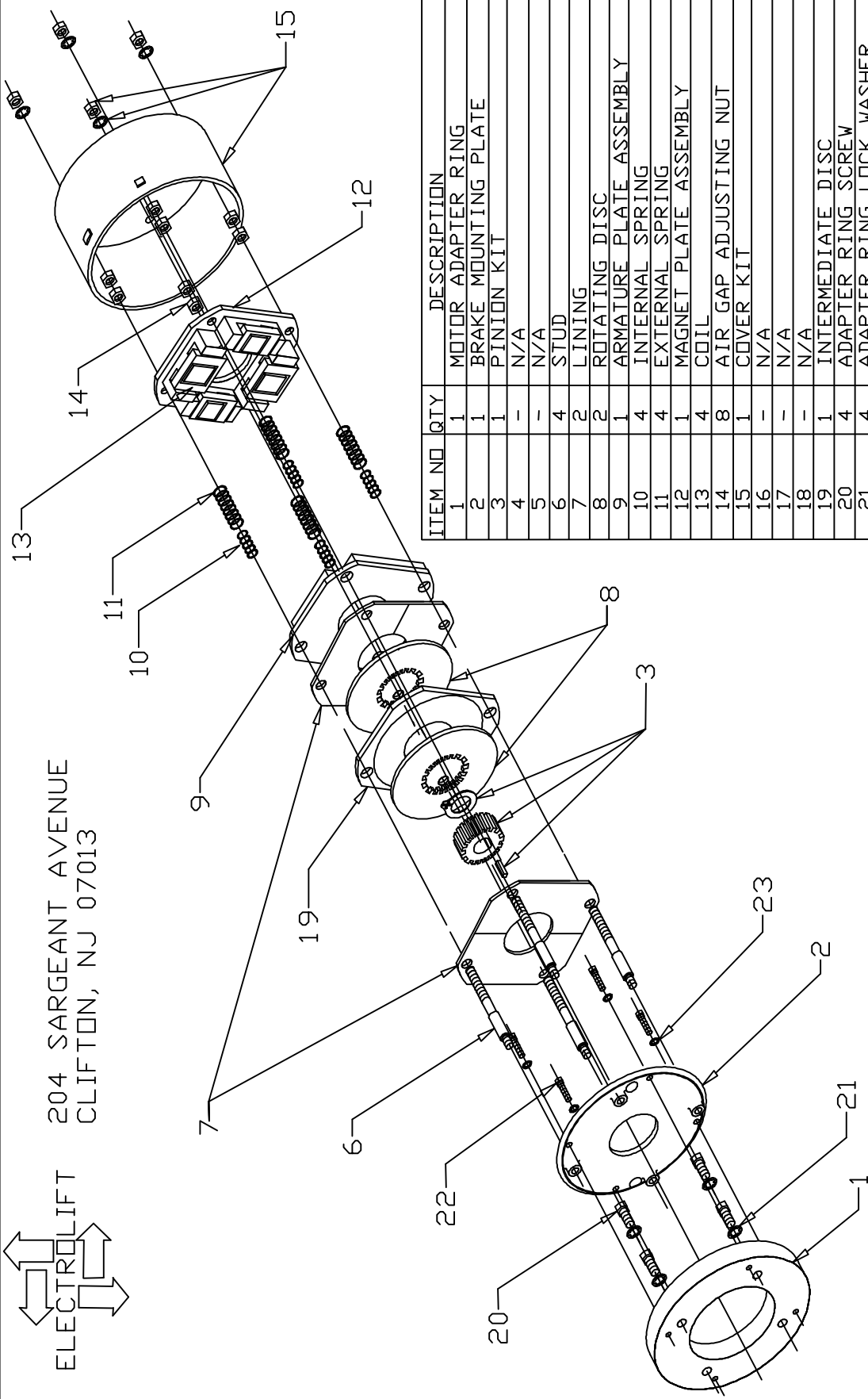

ITEM NO	QTY	DESCRIPTION
1	1	MOTOR ADAPTER RING
2	1	BRAKE MOUNTING PLATE
3	1	PINION KIT
4	-	N/A
5	-	N/A
6	4	STUD
7	2	LINING
8	2	ROTATING DISC
9	1	ARMATURE PLATE ASSEMBLY
10	4	INTERNAL SPRING
11	4	EXTERNAL SPRING
12	1	MAGNET PLATE ASSEMBLY
13	4	COIL
14	8	AIR GAP ADJUSTING NUT
15	1	COVER KIT
16	-	N/A
17	-	N/A
18	-	N/A
19	1	INTERMEDIATE DISC
20	4	ADAPTER RING SCREW
21	4	ADAPTER RING LOCK WASHER
22	4	BRAKE MOUNTING PLATE SCREW
23	4	BRAKE MOUNTING PLATE LOCK WASHER

SHEET 831-2  
REV-1

ELECTRO LIFT DOUBLE DISC PACKAGE BRAKE

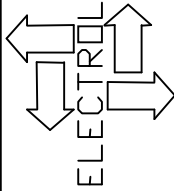

204 SARGEANT AVENUE  
CLIFTON, NJ 07013

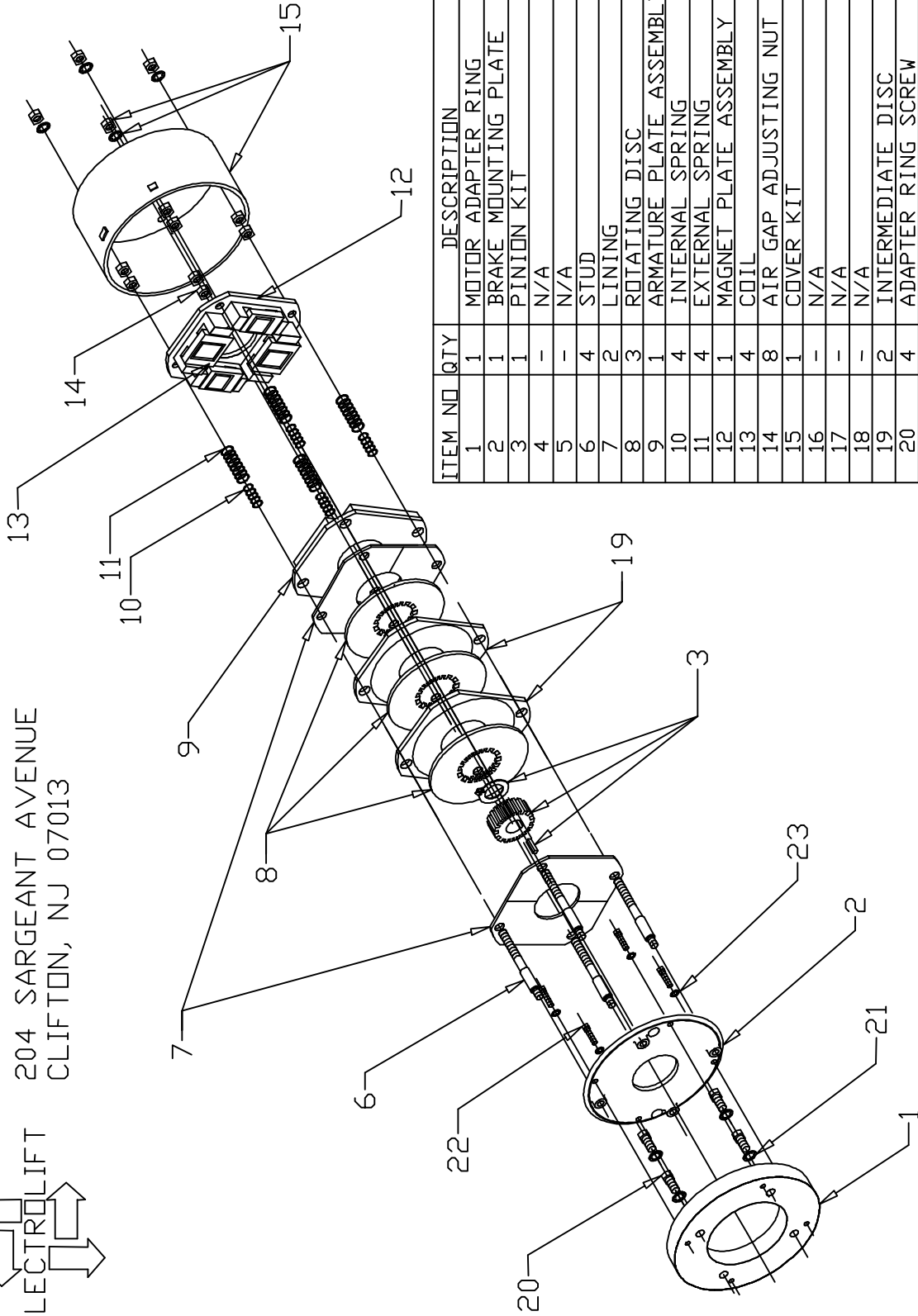

ITEM NO	QTY	DESCRIPTION
1	1	MOTOR ADAPTER RING
2	1	BRAKE MOUNTING PLATE
3	1	PINION KIT
4	-	N/A
5	-	N/A
6	4	STUD
7	2	LINING
8	3	ROTATING DISC
9	1	ARMATURE PLATE ASSEMBLY
10	4	INTERNAL SPRING
11	4	EXTERNAL SPRING
12	1	MAGNET PLATE ASSEMBLY
13	4	COIL
14	8	AIR GAP ADJUSTING NUT
15	1	COVER KIT
16	-	N/A
17	-	N/A
18	-	N/A
19	2	INTERMEDIATE DISC
20	4	ADAPTER RING SCREW
21	4	ADAPTER RING LOCK WASHER
22	4	BRAKE MOUNTING PLATE SCREW
23	4	BRAKE MOUNTING PLATE LOCK WASHER

SHEET 831-3  
REV-1

ELECTRO LIFT TRIPLE DISC PACKAGE BRAKE