

CAPACITY 1000 LBS.

INFORMATION REQUIRED
SEE SHEET 2 FOR SPECIFICATIONS

TRACK SIZE:

FLANGE WIDTH:

FLANGE THICKNESS:

DIMENSION "A": _____

SPACER REQUIRED:

- NO
 YES

DIMENSION "B": _____

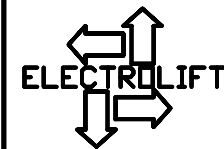

ELECTROLIFT, INC.
204 SARGEANT AVE.
CLIFTON, NJ 07013
PH: 973-471-0204
FAX: 973-471-2814
www.electrolift.com

REV.	ECO#	DATE	BY:
------	------	------	-----

IDLER TROLLEY PART NUMBER: M2655B

DATE: 12/12/07	SCALE: NONE	DWG SIZE: A	DRAWN BY: DR
----------------	-------------	-------------	--------------

DRAWING NO:

M2655B-WPDF
SHEET 1 OF 2

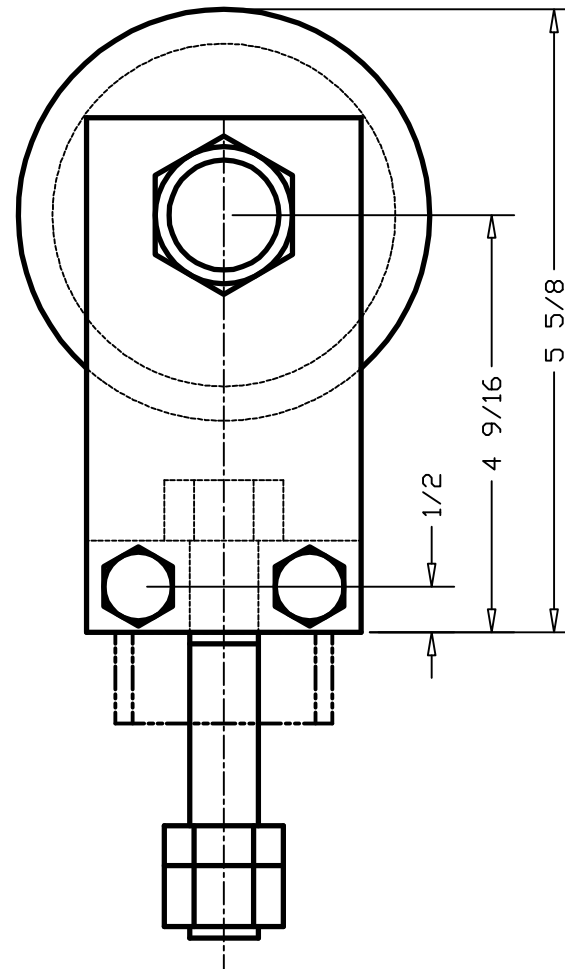
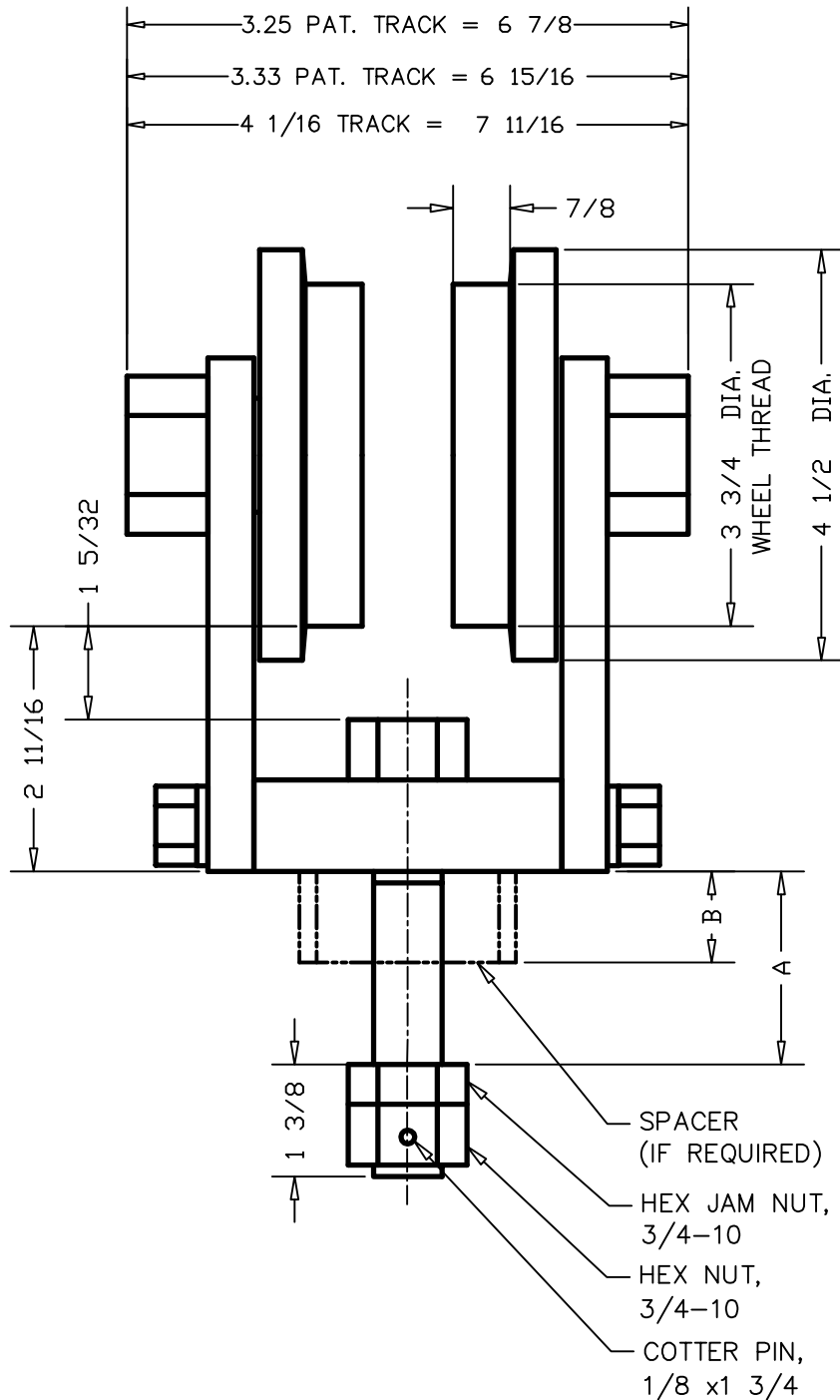

**CAPACITY
1000 LBS.**

SPECIFICATIONS

PROVIDE SHEET 1 TO ELECTROLIFT

GENERAL NOTES:

1. CAPACITY OF TROLLEY IS NOT TO BE EXCEEDED
2. FACTOR OF SAFETY 5 TO 1 MINIMUM
3. VISTA GREEN ENAMAL PAINT STANDARD
4. NOT DESIGNED FOR TRAVERSING TRACKS WITH A RADIUS.
5. CONSULT ELECTROLIFT'S SALES DEPARTMENT FOR ADDITIONAL FEATURES

WHEEL ASSEMBLY

STANDARD HARDENED WHEEL:
BRINELL 475/ROCKWELL C50
BEARING L10HR LIFE:
36,191 HRS AT 50 FPM

TRACK TYPE

PATENTED TRACKS: FLAT PROFILE AS SHOWN
S-BEAM TRACK: SEE TROLLEY M1168B
W-BEAM TRACK: SEE TROLLEY M1168B

SPACER LENGTH

REQUIRED IF DIMENSION "C"
EXCEEDS 1/2"
MATERIAL = TUBING, 2 IDx2-3/8 OD

BOLT SPAN

2" MAX.
FOR LARGER DIMENSIONS,
CONTACT
ELECTROLIFT

GAP

1/8" MIN. GAP REQUIRED
FROM BOTTOM OF YOKE
OR SPACER TO BOTTOM
OF FRAME

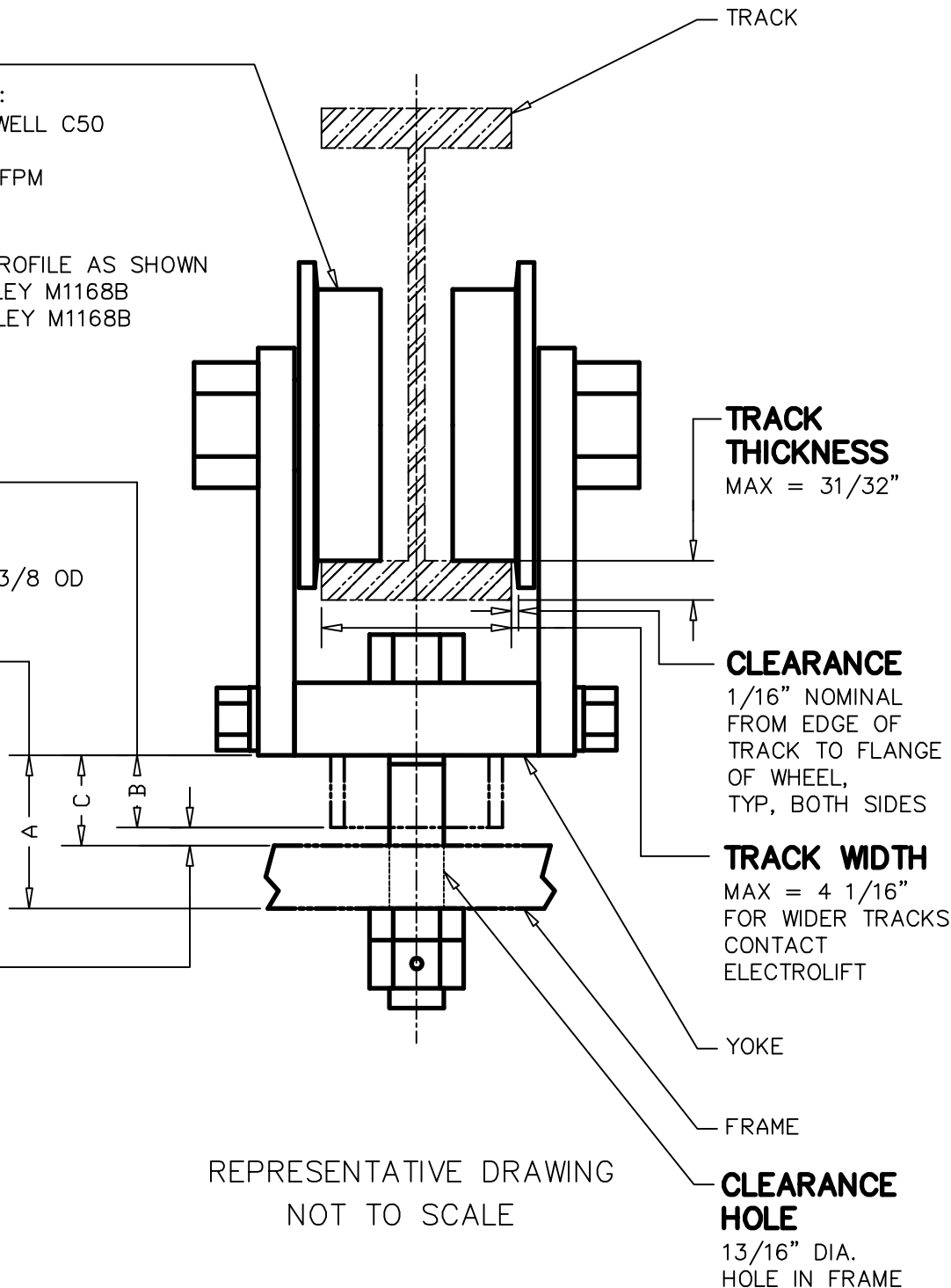

REPRESENTATIVE DRAWING
NOT TO SCALE

CLEARANCE HOLE
13/16" DIA.
HOLE IN FRAME

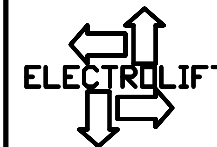

ELECTROLIFT, INC.
204 SARGEANT AVE.
CLIFTON, NJ 07013
PH: 973-471-0204
FAX: 973-471-2814
www.electrolift.com

REV.	ECO#	DATE	BY:
IDLER TROLLEY PART NUMBER: M2655B			
DATE: 12/12/07	SCALE: NONE	DWG SIZE: A	DRAWN BY: DR
DRAWING NO: M2655B-WPDF			
SHEET 2 OF 2			