

ELECTROLIFT
Customer Service
1-800-338-9951

OUTER SURFACE

SEAL

SEAL TO BE FLUSH WITH
OUTER SURFACE, ITEM 5 AND ITEM 19
SEAL ORIENTATION ITEM 9
OR ITEM 16

PARTIAL SECTION VIEW A

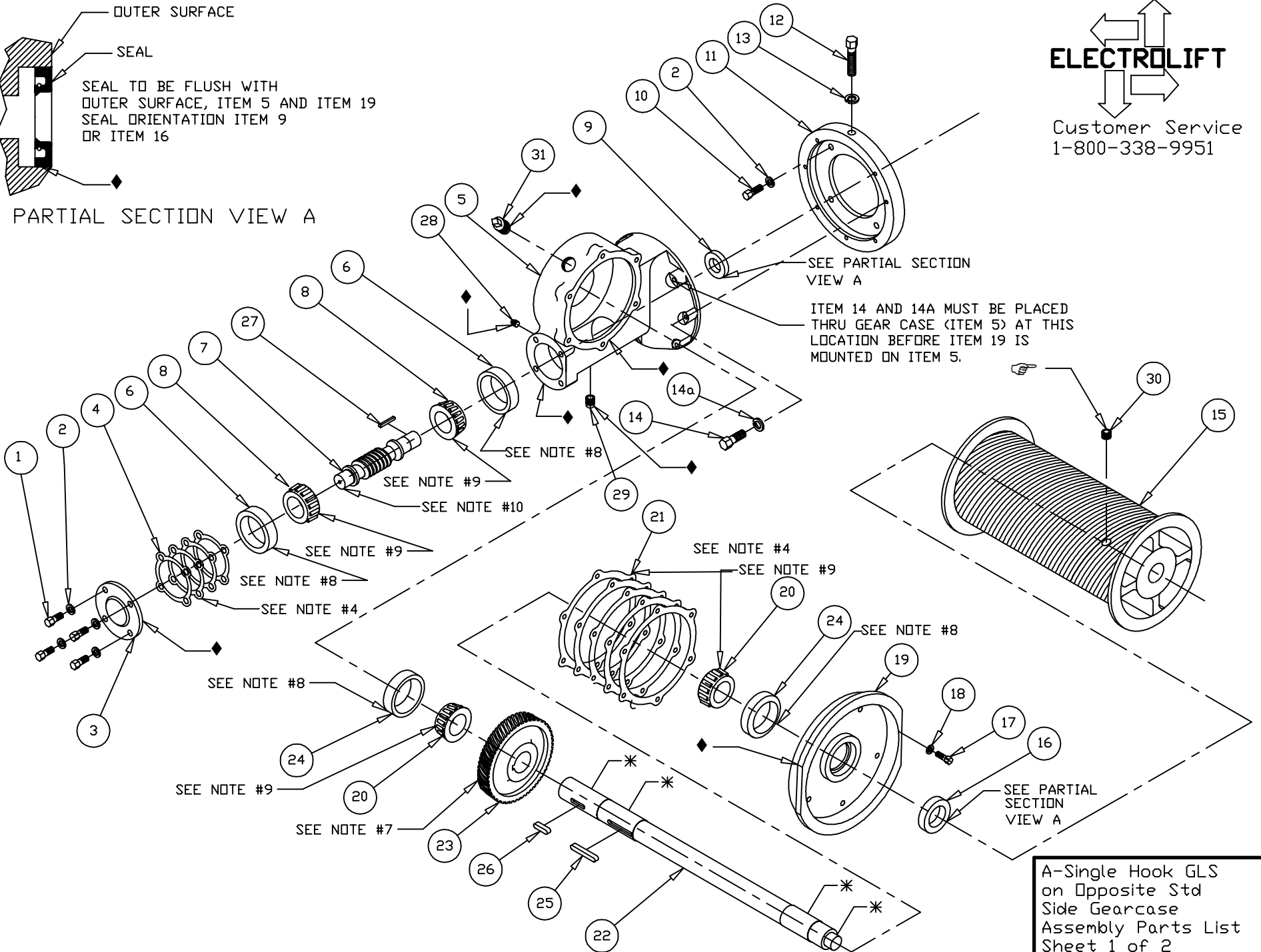

A-Single Hook GLS
on Opposite Std
Side Gearcase
Assembly Parts List
Sheet 1 of 2

31	FS337	1	PIPEPLUG,1/2 SQHD CORED,W/STRAIGHT VENT ☒SEE NOTE A
30	FS445	1	SOCKET HEAD SET SCREW 3/8-16x1/2, KNURLED
29	FS333	1	PIPEPLUG,1/2 SQHD CORED,CI PLAIN ☒SEE NOTE A
28	FS336	1	PIPEPLUG,1/8 SQHD,CAST IRON, SOLID ☒SEE NOTE A
27	K10845P2	1	KEY, 3/16x3/16, 1-1/16, A MOTOR
26	K10849P4	1	KEY, 5/16x5/16, 1-1/4, "A" WORM WHEEL
25	K10849P5	1	KEY, 5/16x5/16, 2, A:B DRUM SHAFT
24	DM7004	2	BEARING, TRB, CUP, 3.00 OD ☒SEE NOTE B
23	----	1	WORM WHEEL, SEE NOTE #5
22	----	1	SHAFT, JOB SPECIFIC
21	K10753	1	KIT, SHIM, A-HOIST, SIDE COVER
20	DM7003	2	BEARING, TRB, CONE, 1.50 ID ☒SEE NOTE B
19	M388	1	COVER, SIDE, GEAR CASE, A
18	FS312	6	WASHER,L,5/16, PLAIN ☒SEE NOTE A
17	FS122	6	SCREW,HHCS,5/16-18x7/8 ☒SEE NOTE A
16	DM7028	2	SEAL, SHAFT, 1.5 ID, 2.37 OD ☒SEE NOTE C
15	----	1	DRUM, JOB SPECIFIC
14a	FS310	7	WASHER,L,1/4 ☒SEE NOTE A
14	FS571	7	SCREW,HHCS,1/4-20x1-1/2 ☒SEE NOTE A
13	FS323	1	WASHER,L,1/2 ☒SEE NOTE A
12	FS148	1	SCREW,HHCS,1/2-13x2-1/4 ☒SEE NOTE A
11	M2960	1	ADAPTER, MOTOR
10	FS129	4	SCREW,HHCS,3/8-16x1 ☒SEE NOTE A
9	DM7216	1	SEAL, SHAFT, 1 ID, 1.82 OD ☒SEE NOTE C
8	DM7000	2	BEARING, TRB, CONE, 1 ID ☒SEE NOTE B
7	----	1	WORM SHAFT, SEE NOTE #5
6	DM7001	2	BEARING, TRB, CUP, 2.56 OD ☒SEE NOTE B
5	M12143	1	GEAR CASE, A HOIST, GLS
4	K10754	1	KIT, SHIM, A-HOIST, END COVER
3	K101	1	COVER, END, GEAR CASE, A
2	FS315	8	WASHER,L,3/8 ☒SEE NOTE A
1	FS466	4	SCREW,HHCS,3/8-16x7/8 ☒SEE NOTE A
ITEM #	PART #	QTY	DESCRIPTION

BILL OF MATERIALS

NOTES:

- 1) * - APPLY ANTISEIZE COMPOUND
- 2) ◆ - SEE LAST SHEET FOR LOCTITE SEALANT AND GASKET APPLICATION INSTRUCTIONS.
- 3) ☞ - APPLY BLUE TYPE THREADLOCK COMPOUND, TORQUE TO 24 FT-LBS
- 4) USE THE SAME AMOUNT AND COLOR OF SHIMS AS ORIGINAL SET.
- 5) IDENTIFICATION CHART

NO OF TEETH	WORM WHEEL P/N	WORM SHAFT P/N
44	M302	M301 P1
55	M2856A	M2855
64	K903A	K940
- 6) OIL CAPACITY 12 OZ., EXXON CYLESSTIC TK680 OR EQUIV. E/L P/N DM7146 OR MOBIL SHC 634 OR EQUIV. (SYNTHETIC) E/L P/N DM7381
- 7) PRESS ITEM 23 ONTO ITEM 22 CENTRALLY LOCATED ON ITEM 26
- 8) PRESS ITEM INTO MATING HOUSING OR COVER
- 9) TO BE PRESSED ON MATING SHAFT
- 10) TAP WITH MALLETT AFTER PRESSING ITEM 6

☒ KIT NOTES:

- A) THIS PART CAN ONLY BE ORDERED AS PART OF GEARCASE HARDWARE KIT #K11254
- B) THIS PART CAN ONLY BE ORDERED AS PART OF GEARCASE BEARING KIT #K11151.
- C) THIS PART CAN ONLY BE ORDERED AS PART OF SEAL KIT #K11153.

D) FOR BOTH SEALS & SHIMS, ORDER SEAL & SHIM KIT #K11279.

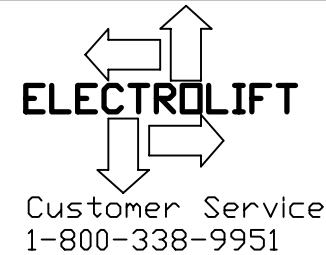

A-Single Hook GLS on Opposite Std Side Gearcase Assembly Parts List Sheet 2 of 2

Type 'A', 'B', and 'BC' Hoist Gearbox

Notes:

1. Required components: 518 Gasket Eliminator, 565 Pipe Sealant, 598 RTV, and 7649 Primer
1. All metal surfaces to be cleaned with brake cleaner, acetone, or Loctite Cleaner/Degreaser. After cleaning, all surfaces will be wiped down and dried.
2. All Loctite sealants, retaining compounds, and gasket eliminators require 3 hours to set and 24 hours to fully cure. None of these materials should come into contact with oil or grease before this time.
4. Apply 518 Gasket Eliminator in a continuous bead, circling each bolt hole as shown. Do not spread.

Issue 1, 5/28/15

Gearcase / Side Cover - 518 Gasket Eliminator

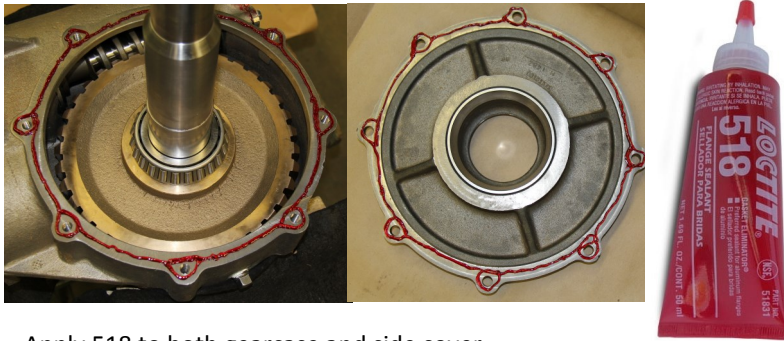

Apply 518 to both gearcase and side cover

Gearcase / End Cover - 518 Gasket Eliminator

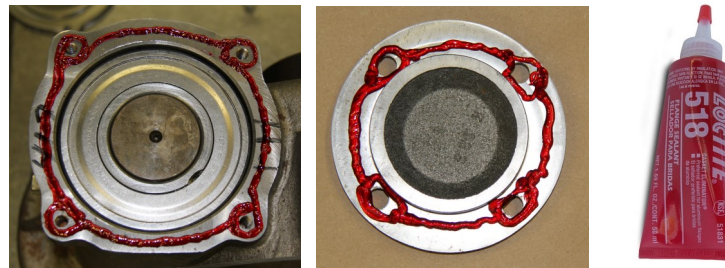

Shims (Side Cover or End Cover) - 7649 Primer



Note:

Spray both sides of the shim 'stack' with Loctite 7649 Primer. There is no need to spray each shim individually.

Spur Gear Cover / Side Plate (if equipped) - 518 Gasket Eliminator



Oil Seal - 598 RTV

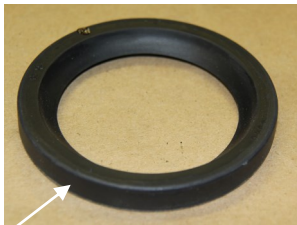

Apply Loctite 598 RTV to the outside diameter of the oil seal

Pipe Plug - 565 Sealant



Apply Loctite 565 Pipe Sealant to threads only.

