

ELECTROLIFT
 Customer Service
 1-800-338-9951

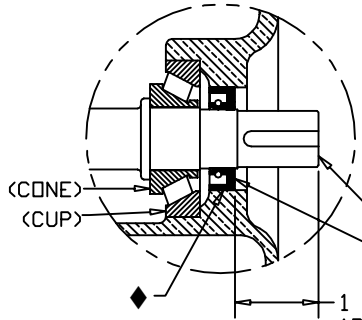

PARTIAL SECTION VIEW A

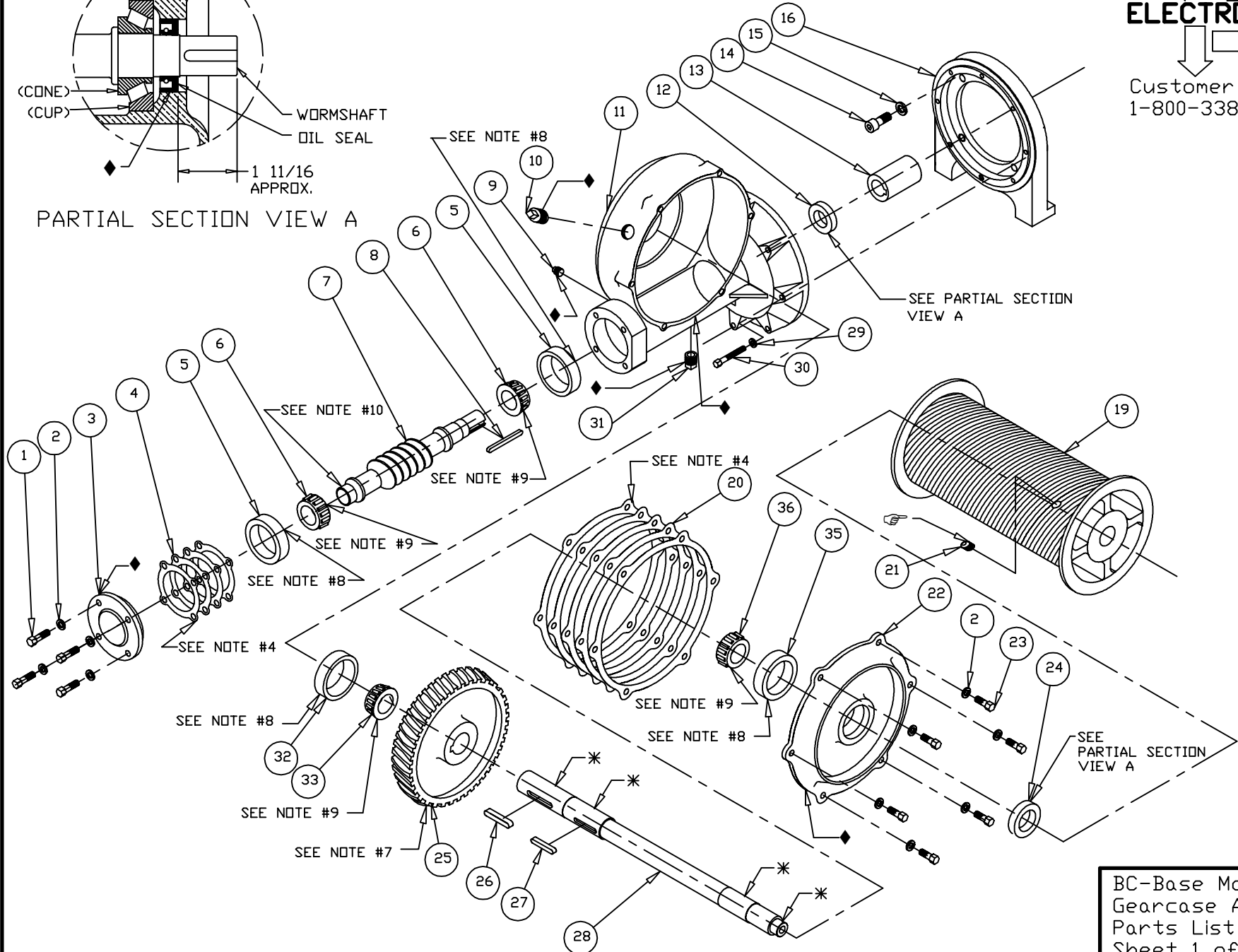

BC-Base Mounted
 Gearcase Assembly
 Parts List
 Sheet 1 of 2

34	N/A	--	--
33	DM7003	1	BEARING, TRB, CONE, 1.50 ID <input checked="" type="checkbox"/> SEE NOTE B
32	DM7004	1	BEARING, TRB, CUP, 3.00 OD <input checked="" type="checkbox"/> SEE NOTE B
31	FS333	1	PIPEPLUG,1/2 SQHD CORED,CI PLAIN <input checked="" type="checkbox"/> SEE NOTE A
30	FS127	7	SCREW,HHCS,5/16-18x2-1/4, GR2,PLAIN <input checked="" type="checkbox"/> SEE NOTE A
29	FS312	7	WASHER,L,5/16, PLAIN <input checked="" type="checkbox"/> SEE NOTE A
28	----	1	DRUM SHAFT, JOB SPECIFIC
27	K10910P7	1	KEY,1/2x1/2x2-5/8,DRUM,C,3P,D
26	K10910P4	1	KEY,1/2x1/2x1-15/16,C:BC WORM WH
25	----	1	WORM WHEEL, SEE NOTE #5
24	DM7031	1	SEAL,SHAFT,2.25 ID, 3.35 OD <input checked="" type="checkbox"/> SEE NOTE C
23	FS129	6	SCREW,HHCS,3/8-16x1,GR2,PLAIN <input checked="" type="checkbox"/> SEE NOTE A
22	M1310B	1	COVER, SIDE, GEAR CASE,BC
21	FS216	1	SCREW,SHSS,1/2-13x1/2,KNURLED
20	K10755	1	KIT, SHIM, B-HOIST, SIDE COVER
19	----	1	DRUM, JOB SPECIFIC
18	N/A	--	--
17	N/A	--	--
16	M2959E	1	ADAPTER, MOTOR, T477, C FACE, FLR & BASE MTD
15	FS320	4	WASHER,INT.TOOTH,1/2,PLATED <input checked="" type="checkbox"/> SEE NOTE A
14	FS207	4	SCREW, SHCS, 1/2-13x1-1/4 <input checked="" type="checkbox"/> SEE NOTE A
13	K122P2	1	SLEEVE, MOTOR SHAFT, B HOIST
12	DM7030	1	SEAL, SHAFT, 1.18 ID, 2.06 OD <input checked="" type="checkbox"/> SEE NOTE C
11	T477BC	1	GEAR CASE, BC HOIST
10	FS337	1	PIPEPLUG,1/2 SQHD CORED, W/STRAIGHT VENT <input checked="" type="checkbox"/> SEE NOTE A
9	FS336	1	PIPEPLUG,1/8 SQHD,CAST IRON, SOLID <input checked="" type="checkbox"/> SEE NOTE A
8	K10849P3	1	KEY, 5/16x5/16, 2-15/16
7	----	1	WORM SHAFT, SEE NOTE #5
6	DM7005	2	BEARING, TRB, CONE, 1.25 OD <input checked="" type="checkbox"/> SEE NOTE B
5	DM7006	2	BEARING, TRB, CUP, 3.125 OD <input checked="" type="checkbox"/> SEE NOTE B
4	K10756	1	KIT, SHIM, B-HOIST, END COVER
3	K123	1	COVER, END, GEAR CASE, B
2	FS315	10	WASHER,L,3/8, PLAIN <input checked="" type="checkbox"/> SEE NOTE A
1	FS130	4	SCREW,HHCS,3/8-16x1-1/4,GR2,PLAIN <input checked="" type="checkbox"/> SEE NOTE A
ITEM #	PART #	QTY	DESCRIPTION

BILL OF MATERIALS

NOTES:

- 1) * - APPLY ANTISEIZE COMPOUND
- 2) ♦ - SEE LAST SHEET FOR LOCTITE SEALANT AND GASKET APPLICATION INSTRUCTIONS.
- 3)  - APPLY BLUE TYPE THREADLOCK COMPOUND, TORQUE TO 24 FT-LBS
- 4) USE THE SAME AMOUNT AND COLOR OF SHIMS AS ORIGINAL SET.
- 5) IDENTIFICATION CHART

NO OF TEETH	WORM WHEEL P/N	WORM SHAFT P/N
36	M336A	M320
41	M12207A	M2851
67	M2864A	M2853
- 6) OIL CAPACITY 20 OZ.
EXXON CYLESSTIC TK680 OR EQUIV. E/L P/N DM7146
OR MOBIL SHC 634 OR EQUIV. (SYNTHETIC) E/L P/N DM7381
- 7) PRESS ITEM 25 ONTO ITEM 28 CENTRALLY LOCATED ON ITEM 26
- 8) PRESS ITEM INTO MATING HOUSING OR COVER
- 9) TO BE PRESSED ON MATING SHAFT
- 10) TAP WITH MALLET AFTER PRESSING ITEM 5

KIT NOTES:

- A) THIS PART CAN ONLY BE ORDERED AS PART OF GEARCASE HARDWARE KIT #K11236.
- B) THIS PART CAN ONLY BE ORDERED AS PART OF GEARCASE BEARING KIT #K11158.
- C) THIS PART CAN ONLY BE ORDERED AS PART OF SEAL KIT #K11159.
- D) FOR BOTH SEALS & SHIMS, ORDER SEAL & SHIM KIT #K11282.

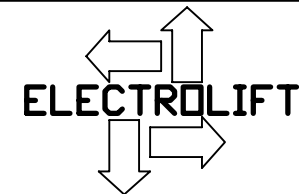

Customer Service
1-800-338-9951

36	DM7009	1	BEARING, TRB, CONE, 2.25 ID <input checked="" type="checkbox"/> SEE NOTE B
35	DM7010	1	BEARING, TRB, CUP 4.25 OD <input checked="" type="checkbox"/> SEE NOTE B
ITEM #	PART #	QTY	DESCRIPTION

BILL OF MATERIALS CONT'D

BC-Base Mounted
Gearcase Assembly
Parts List
Sheet 2 of 2

Type 'A', 'B', and 'BC' Hoist Gearbox

Notes:

1. Required components: 518 Gasket Eliminator, 565 Pipe Sealant, 598 RTV, and 7649 Primer
1. All metal surfaces to be cleaned with brake cleaner, acetone, or Loctite Cleaner/Degreaser. After cleaning, all surfaces will be wiped down and dried.
2. All Loctite sealants, retaining compounds, and gasket eliminators require 3 hours to set and 24 hours to fully cure. None of these materials should come into contact with oil or grease before this time.
4. Apply 518 Gasket Eliminator in a continuous bead, circling each bolt hole as shown. Do not spread.

Issue 1, 5/28/15

Gearcase / Side Cover - 518 Gasket Eliminator

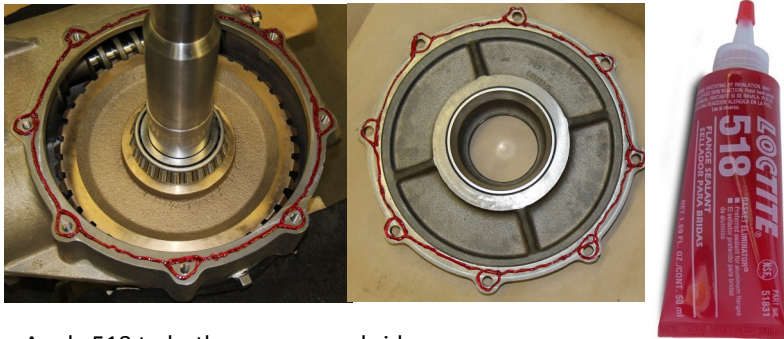

Apply 518 to both gearcase and side cover

Gearcase / End Cover - 518 Gasket Eliminator

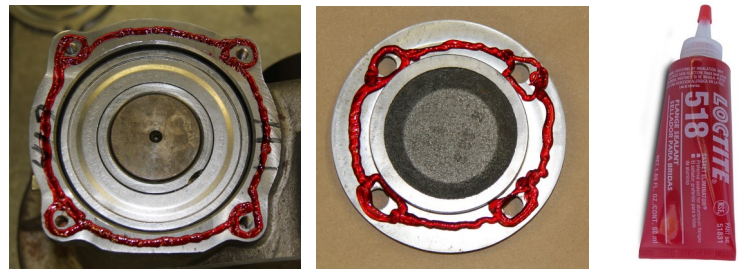

Shims (Side Cover or End Cover) - 7649 Primer



Note:

Spray both sides of the shim 'stack' with Loctite 7649 Primer. There is no need to spray each shim individually.

Spur Gear Cover / Side Plate (if equipped) - 518 Gasket Eliminator



Oil Seal - 598 RTV

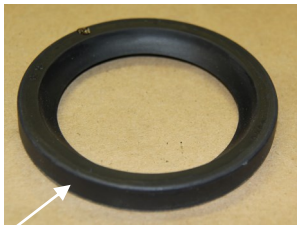

Apply Loctite 598 RTV to the outside diameter of the oil seal

Pipe Plug - 565 Sealant



Apply Loctite 565 Pipe Sealant to threads only.

