

STANDARD HOOK ASSEMBLY
CONTACT ELECTROLIFT'S
SALES DEPARTMENT FOR
OTHER OPTIONS.

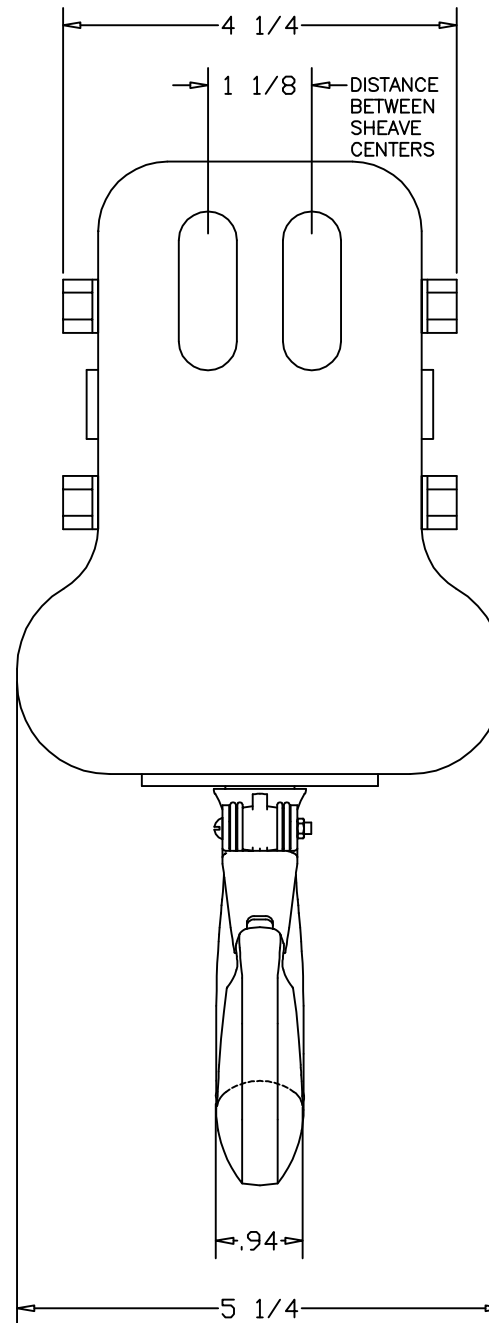

CAPACITY
2000 LBS.

FACTOR OF SAFETY
5 TO 1 MINIMUM

SPECIFICATIONS:

1. WIRE ROPE:

FOR USE WITH 1/4" OR 5/16"
DIAMETER WIRE ROPE

2. SHEAVES:

QUANTITY = 2
PITCH DIAMETER = 5"
MATERIAL =

FOR STANDARD DUTY:
CAST IRON SHEAVE
WITH BRONZE BEARING

FOR HEAVY DUTY
(UPON REQUEST):
STEEL SHEAVE WITH
BRONZE BEARING

4. HOOK ASSEMBLY PART NUMBER:

P531P8 HOOK ASSEMBLY MADE
FROM CROSBY S-319CN 2 TON
CARBON HOOK PART #1028532

5. WEIGHT:

20 LBS

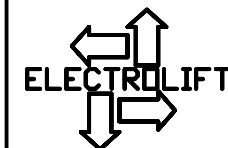

ELECTROLIFT, INC.
204 SARGEANT AVE.
CLIFTON, NJ 07013
PH: 973-471-0204
FAX: 973-471-2814
www.electrolift.com

REV.	ECO#	DATE	BY:
STANDARD HOOK BLOCK:			
M1047A			
DATE:	SCALE:	DWG SIZE:	DRAWN BY:
2/26/08	1/2	A	DR

DRAWING NO:
M1047A-WPDF